

IMPORTANT: READ THE FOLLOWING INFORMATION BEFORE OPERATING YOUR:

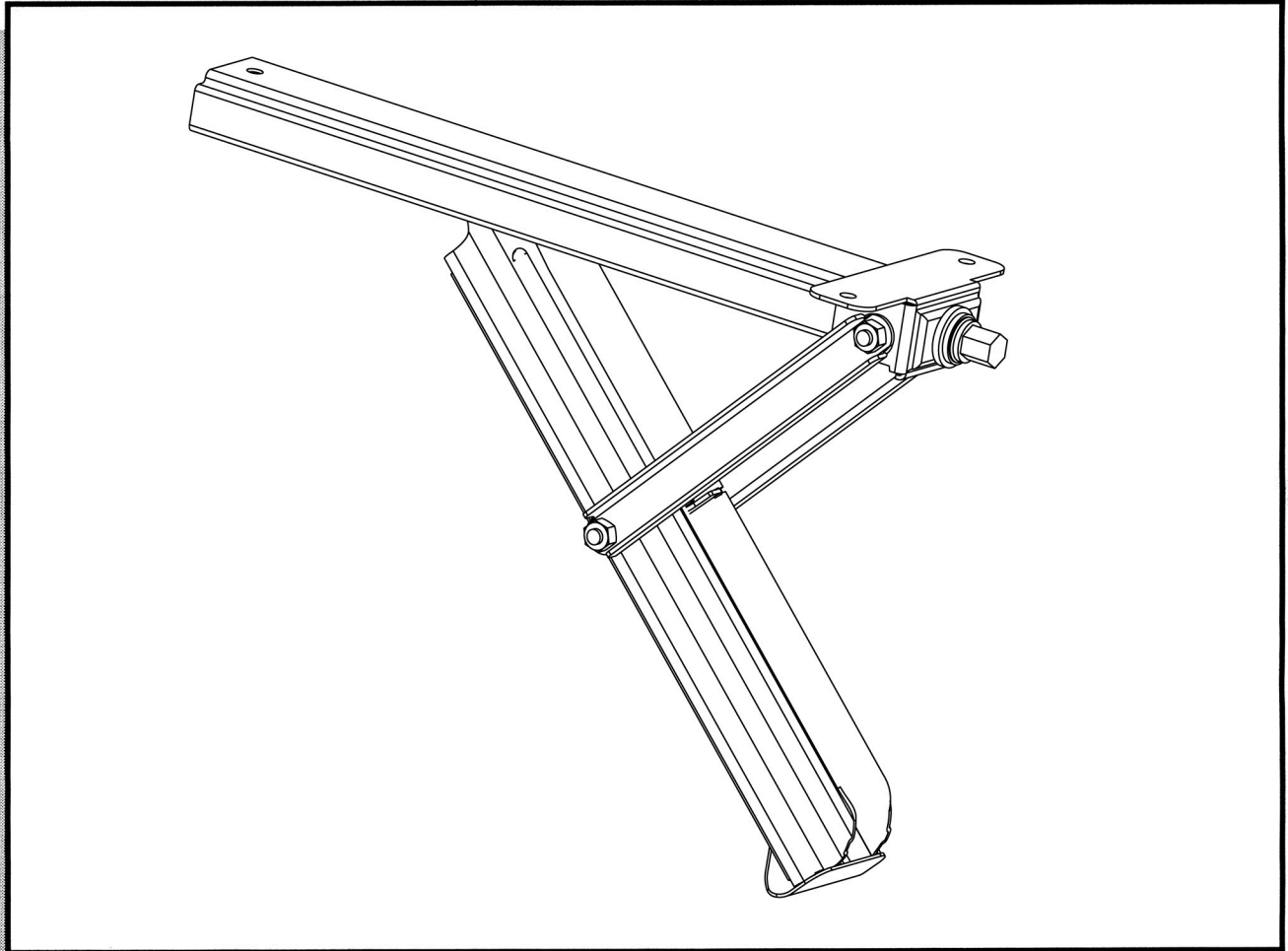

19", 22", 25", 28" and 31"
"C" TYPE STABILIZING JACK
FOR USE ON TRAVEL TRAILERS AND 5TH WHEEL TRAILERS

INSTALLATION AND OPERATING INSTRUCTIONS



THIS TELESCOPIC STABILIZING JACK IS DESIGNED FOR:
FINE LEVELING AND STABILIZING TRAVEL TRAILERS AND 5TH WHEEL TRAILERS.



SAFETY WARNINGS:



- **DO NOT** ATTEMPT TO USE THIS STABILIZING JACK TO LIFT EXCESSIVE WEIGHT OR TIRES OFF OF THE GROUND - VEHICLE FRAME AND DOOR JAM DAMAGE MAY OCCUR. USE ONLY STOCK HANDLE SUPPLIED.
- **DO NOT** ATTEMPT TO USE THIS STABILIZING JACK FOR ANY PURPOSE OTHER THAN ITS INTENDED DESIGN.

PARTS LIST

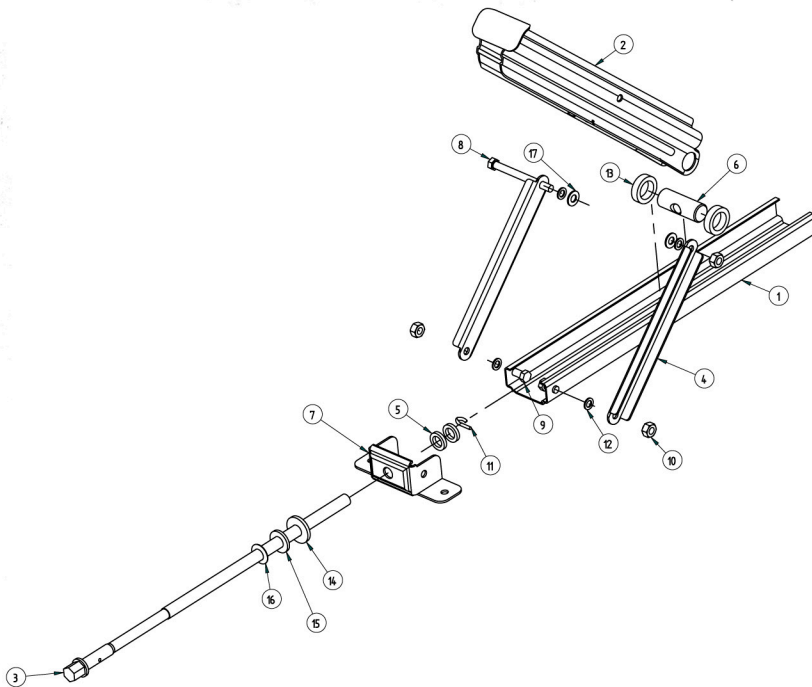

Item #	Part #	Description	Quantity
	P232191	INSTALLATION KIT	
1	P855151	C-CHANNEL, 19" C-JACK	1
	P855141	C-CHANNEL, 22" C-JACK	1
	P855131	C-CHANNEL, 25" C-JACK	1
	P855121	C-CHANNEL, 28" C-JACK	1
	P855111	C-CHANNEL, 31" C-JACK	1
2	P855150	ARM, 19" C-JACK	1
	P855140	ARM, 22" C-JACK	1
	P855130	ARM, 25" C-JACK	1
	P855120	ARM, 28" C-JACK	1
	P855110	ARM, 31" C-JACK	1
3	P855153	DRIVE ROD, 19" C-JACK	1
	P855143	DRIVE ROD, 22" C-JACK	1
	P855133	DRIVE ROD, 25" C-JACK	1
	P855123	DRIVE ROD, 28" C-JACK	1
	P855113	DRIVE ROD, 31" C-JACK	1
4	P855152	LINK, 19" C-JACK	2
	P855142	LINK, 22" C-JACK	2
	P855132	LINK, 25" C-JACK	2
	P855122	LINK, 28" C-JACK	2
	P855112	LINK, 31" C-JACK	2
5	BAL2112	1" OD X 5/8" ID X .179 WASHER	2
6	P857061	SCISSOR JACK DRIVE TRUNION	1
7	P855100	T-BRACKET, C- JACK	1
8	R853048	3/8-16 x 4.0 HEX BOLT GRADE 2	1
9	502113	3/8-16 x .75 HEX BOLT GRADE 2	2
10	501063	NUT 3/8-16 HEX METAL LOCK C Z	3
11	R857076	HUBBARD, HAIR PIN CLIP	1
12	502103	5/8 OD X 3/8 ID X .06 NYLON WASHER	4
13	857088	SPACER, PLASTIC, 1.02ID X 1.5 OD X .40	2
14	BAL2111	5/8ID X 1.5OD X .18 CUPPED WASHER	1
15	857038	5/8ID X 1.25OD X .15 NYLON 6/6 WASHER	1
16	R12191	BELLEVILLE WASHER, 5/8ID X 1 1/8OD X .028	1
17	502090	3/8" WASHER, ZINC	2

DETERMINING CORRECT MOUNTING LOCATION

NOTE: CHECK GROUND CLEARANCE PRIOR TO INSTALLATION.

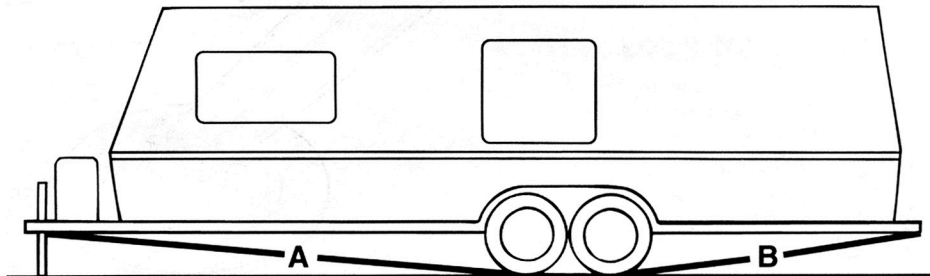

TRAVEL TRAILER AND 5TH WHEEL TRAILER MOUNTING PLACEMENT

WHEN SELECTING PLACEMENT FOR INSTALLATION...

- Be sure that there is adequate ground clearance.
- Be sure that drive screw is accessible.

STEP 1: PARK ON LEVEL GROUND

FRONT: Draw a string from the front corner of the trailer frame to the bottom of the front tire (A).

REAR: Draw a string from the bottom of the back tire to the back corner of the trailer frame (B).

NOTE: ANY OBJECT PROTRUDING BELOW THESE LINES CAN BE DAMAGED, DRAGGED OFF OR DESTROYED IN UNEVEN TERRAIN (ENTERING OR EXITING DRIVEWAYS, DRIVING OFF ROAD, ETC.)

INSTALLATION WITHOUT CENTER SUPPORT CHANNEL

DIFFERENT JACK SIZES AVAILABLE TO WORK ON ALL TRAILER MODELS

BAL "C" Type Stabilizers are designed to mount to the trailer frame where the crossmember meets the main frame member. On some trailers the frame is enclosed with an underskin. To find frame crossmembers, locate screw or rivet line that uses a crossmember to support the underskin.

NOTE: Using the criteria above under the title "Determining Correct Mounting Location", do the following:

- Find the closest existing crossmember to secure the "C" stabilizer and provide clear ground clearance.
- If there is no crossmember at the desired location, use a support channel to support the inside channel of both jacks. For 19", 22" & 25" jacks, use #23205 (42" channel). For 28" & 31" jacks, use #23206 (31" channel). Proceed with installation.

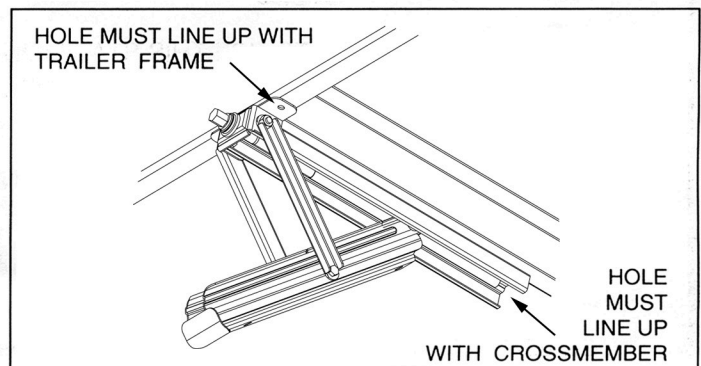

INSTALLATION WITH CENTER SUPPORT CHANNEL

Tools required: hammer, center punch, high speed drill, 13/64" diameter drill bit, & 3/8" bit socket

NOTE: Park trailer on level ground. Prevent wheels from rolling by using tire chocks, landing gear, or tongue jack.

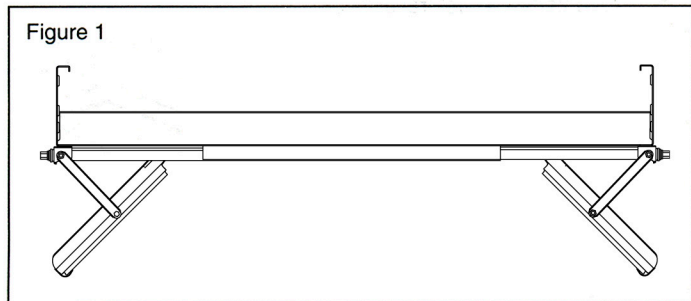

INSTALLATION WITH SELF-DRILLING SCREWS

STEP 1. Remove stabilizer from package and slide channel halves together if telescoping center channel is used. Crank stabilizers partially open so they fit under the trailer frame. Slide entire assembly under trailer frame to location that provides proper ground clearance. Crank open stabilizers to contact trailer frame so that stabilizer assembly supports itself (Figure 1).

NOTE A: Be sure to maintain at least a 6" overlap between the jacks and support channel.

NOTE B: Frame crossmember must be present if center support channel is not used.

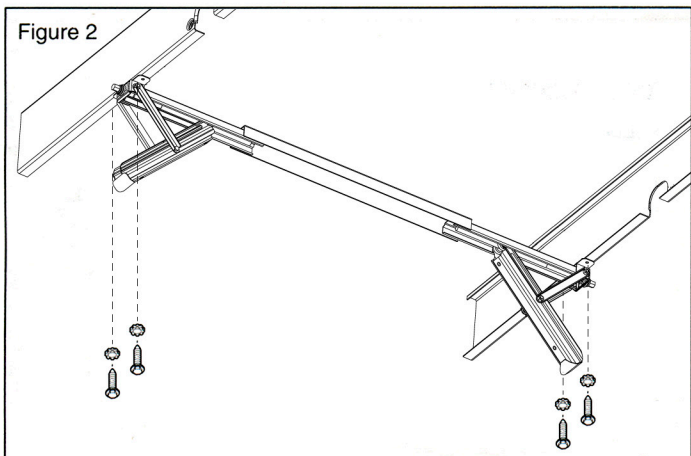

STEP 2. With the stabilizer in the desired location, use the mounting plates as a template. Mark the mounting hole locations on the trailer frame with a center punch. Drill (2 each) 13/64" holes into the trailer frame at each end of the stabilizer assembly corresponding to the holes in the mounting plates.

STEP 3. Using 3/8" socket bit & drill, attach the stabilizer to the trailer frame with four 1/4" self-drilling screws & star washers (Figure 2).

STEP 4. For installations using center support channel, use a small "C" clamp to hold jacks & support channel in place. Drill two 13/64" diameter holes in the overlap area through both jacks and support channel. Using a 3/8" socket, run the 1/4" self-drilling screws with star washers into place (Figure 3). For installations without center support channel, run 1/4" self-drilling screws through hole at end of jacks into crossmember.

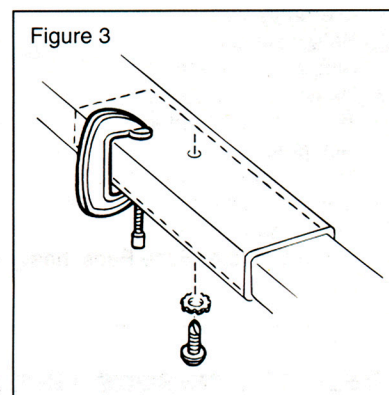

STEP 5. Crank stabilizers up before moving trailer.

WELD-ON INSTALLATION

STEP 1. Refer to Step 1 of "Installation With Self-Drilling Screws".

STEP 2. With stabilizer in desired location, clamp in place and weld (4) 1" welds near mounting holes as shown (Figure 4).

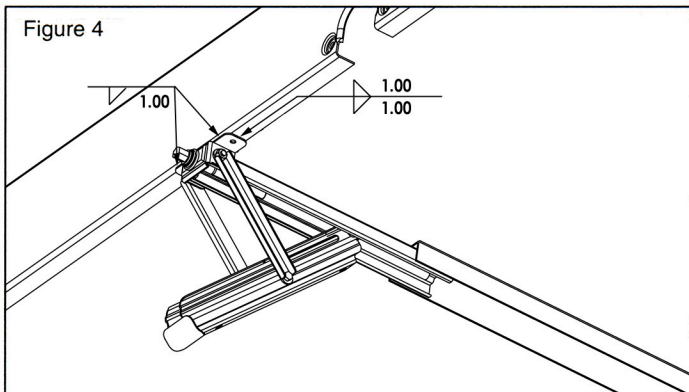

STEP 3. For installations using center support channel, use a small "C" clamp to hold jacks & support channel in place. Drill two 13/64" diameter holes in the overlap area through both jacks and support channel. Using a 3/8" socket, run the 1/4" self-drilling screws with star washers into place (Figure 3). For installations without center support channel, run 1/4" self-drilling screws through hole at end of jacks into crossmember.

STEP 4. Crank stabilizers up before moving trailer.

OPERATION

STEP 1. Park RV on level ground, prevent wheels from rolling by using tire chocks.

STEP 2. Level trailer fore and aft using tongue jack or landing gear.

STEP 3. Check level gauge for low side of trailer, crank down stabilizers on low side first, bringing the trailer to a fine level position.

STEP 4. Crank down stabilizers on opposite side of

trailer to insure maximum stability. Then re-snug stabilizers on low side of trailer if necessary.

NOTE - BEFORE MOVING TRAILER: Crank up stabilizers to fully closed position and tighten 1/4 turn to secure in travel position (this prevents stabilizers from working open due to road vibration).

MAINTENANCE: Use small amounts of WD-40 or similar lubricant on drive screw threads and bolt locations as required.

OTHER FINE BAL PRODUCTS

KING PIN STABILIZING JACK

- Maximum stability for frame overhang
- Sets up in seconds
- Simple to operate
- Heavy duty construction includes heat treated jack post
- Lightweight, easy to store
- Chrome Jacking Handle with rubber grip
- Large diameter Base Pads, heavy duty chain and hooks

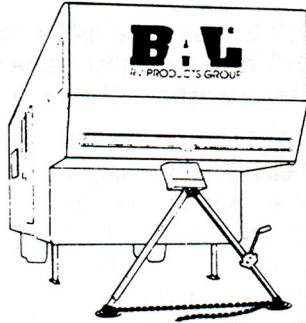

KING PIN LOCK

- Prevents 5th wheel trailer-hitch hook up
- Locks BAL 5th Wheel King Pin Stabilizing Jack to the king pin to prevent theft of BAL Stabilizing Jacks
- Chrome plated
- Die cast for long life
- 2 position lock
- Patented star key design

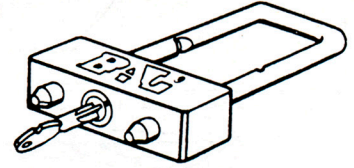

DELUXE SCISSORS TIRE LOCKING CHOCK

- Locks tandem wheels by applying opposing force to tires
- Aids in trailer stabilizing, stops tire shift
- Extends from 2-1/2" to 10"
- Rust inhibitive coating
- Plated ratchet wrench with comfort bumper
- Lightweight, easy to store
- Patents pending

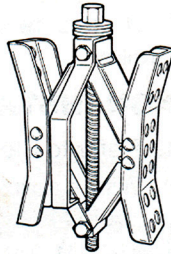

TONGUE TWISTER

- Eliminates trial and error hitch alignment
- Side to side or diagonal placement moves trailer any direction with pin-point accuracy
- Chrome plated ratchet wrench moves trailer with ease
- Rust inhibitive coating

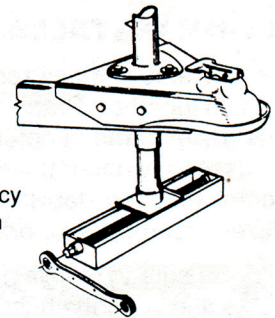

RV STABILIZING JACKS

- Maximum stability up to 36" from the ground to frame
- Heavy duty construction, rust inhibitive coating
- Lightweight and easy to store
- Two piece chrome jacking handle with rubber grip

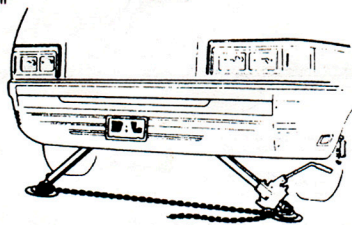

TIRE LOCKING CHOCKS

- Locks tandem wheels by applying opposing force to tires
- Prevents trailer from rolling
- Aids in trailer stabilizing, stops tire shift

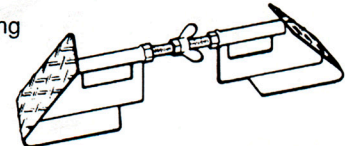

LEVELING SCISSOR JACKS

- Levels and stabilizes
- One unit fits all RV's, front or rear
- Easy to operate
- 5000 lbs. lifting capacity per jack
- Heavy duty, all steel construction
- Rust inhibitive coating

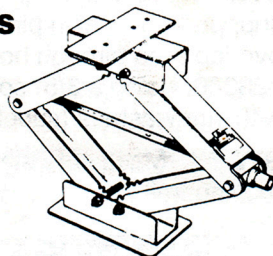

STABILIZER BASE PADS

- 7-1/4" diameter provides a firm footing on loose ground
- Easy to install, all hardware supplied
- Rubber sleeve prevents rattle during travel

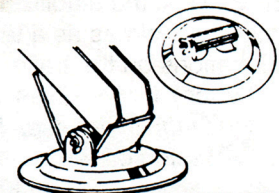

BAL[®]
RV PRODUCTS GROUP

For information or parts contact: BAL RV PRODUCTS GROUP, A Division of Norco Industries Inc.
365 W. Victoria St., Compton, CA 90220, (310) 639-4000 or (213) 636-1176

A DIVISION OF  NORCO INDUSTRIES, INC.