



OWNER'S MANUAL



#2400 (20K) Industry Standard Super 5th

Gross Trailer Weight (Maximum)	20,000 lbs.
Vertical Load Weight (Max. Pin Weight)	4,000 lbs.

The following instructions provide valuable information regarding the function and proper use of the Super 5th Fifth Wheel Towing System.

YOU MUST COMPLETELY READ THE INSTRUCTIONS WITHIN THIS MANUAL, PRIOR TO OPERATING THE HITCH TO PREVENT UNNECESSARY DAMAGE TO THE HITCH, VEHICLE, OR TRAILER.

For more information, please call PullRite at (800) 443-2307.

12.14.15:revA

TABLE OF CONTENTS

SYSTEM WEIGHT RATING vs. COMPONENT WEIGHT RATING	3
LUBRICATION.....	3
KING PIN ADAPTER BALL & COUPLER TUBE	3
ANNUAL MAINTENANCE.....	3
HEIGHT ADJUSTMENT	4
KING PIN ADAPTER INSTALLATION	5
HITCHING	6
SAFETY CHECKS PRIOR TO TOWING.....	6
UNHITCHING	7
CHALLENGE VS. SOLUTION.....	7
#2400 EXPLODED VIEW.....	8
#2400 PARTS LIST	9
5 YEAR LIMITED WARRANTY	I
PRODUCT REGISTRATION	II

SYSTEM WEIGHT RATING vs. COMPONENT WEIGHT RATING

A towing system includes each vehicle and component involved in towing. Each item in your towing system has a capacity or weight rating. Your trailer has a Gross Vehicle Weight Rating, or GVWR. Your truck has a tow capacity, payload capacity, and possibly more. In addition, your fifth wheel hitch has a weight rating. This weight rating must be at, or above, the GVWR of your trailer for you to tow safely. In addition, if your truck can tow larger loads (has a larger capacity) than the rating of your hitch, your system is only safe to tow loads at the lower rating, that of the hitch.

Your mounting kit also has a weight rating, just like your fifth wheel hitch. Many times, these ratings are designed to match. But, this is not always the case. Your mounting kit may be higher rated than your fifth wheel hitch, but it also could be lower depending on the components involved. **The lowest rating of any one component in the system becomes the rating of the entire system.** If your mounting kit is rated to 18,000 lbs., and your hitch is rated at 24,000 lbs., the weight rating of the entire system will not be above 18,000 lbs. Other components in the system could lower the actual system rating further.

It is the end user's responsibility to ensure a safe towing experience. To this end, it is your responsibility to ensure that the truck, trailer, hitching components, and all other items involved are rated or have a capacity sufficient for the loads involved.

LUBRICATION

DO NOT OPERATE HITCH UNTIL YOU READ THIS SECTION!

KING PIN ADAPTER BALL & COUPLER TUBE

The King Pin Adapter Ball and Remote Latch System must be lubricated *before each trip or as needed*. PullRite recommends using a dry graphite spray to prevent the attraction of dust and debris. A light wet lubricant such as WD-40 can also be used, but the two types of lubricants should not be used together.

Be sure the Coupler Tube is free of any obstructions prior to lubrication and before each use. Spray both the Tube and Funnel areas to aid in hitching up.

When lubricating the Remote Latch System using a dry graphite spray, place the latch system in both closed and open positions to cover the spring and pin effectively. If using a wet lube, pull the Release Handle repeatedly between the open and closed positions, so the lubricant is evenly spread among the moving parts.

Be sure the King Pin Adapter Ball is clean and free from rust. A light coating of lubricant should be used before each trip or as needed.

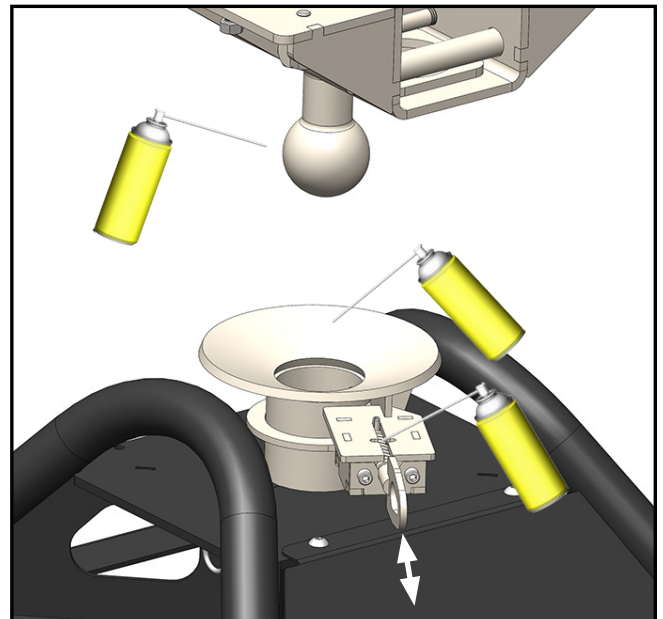

ANNUAL MAINTENANCE

Inspect all mounting brackets and hitch hardware to verify that it is securely fastened. Inspect all mounting bolts for tightness and general condition.

When storing your SuperLite hitch, you should be sure that the coupler and hitch parts are lubricated with WD-40, dry lube, or a combination of both—wet lube for other wear areas such as the contact area between the Hitch Base and the Base Rails where the paint may rub off—to retard the formation of rust. Cover the entire assembly to prevent accumulation of dirt, grime, or rust.

HEIGHT ADJUSTMENT

The #2400 SuperLite is height adjustable and can be set at three positions. Refer to the illustration below and the “#2400 Exploded View” drawing on page 8, following each step below to adjust your hitch’s height:

1. Loosen the three coupler jam nuts (7/8” socket) as well as the three coupler bolts (3/4” socket). It is *not* necessary to remove the bolts - just back out about two complete turns or until the coupler is loose in the base.
2. Remove the clevis pin and clip and adjust to the desired height.
3. Re-pin and clip
4. Torque the three bolts first to 45 ft. lbs., then tighten the jam nuts to 45 ft. lbs. as well. *Over-tightening these bolts could cause damage to the base.* Always torque properly.

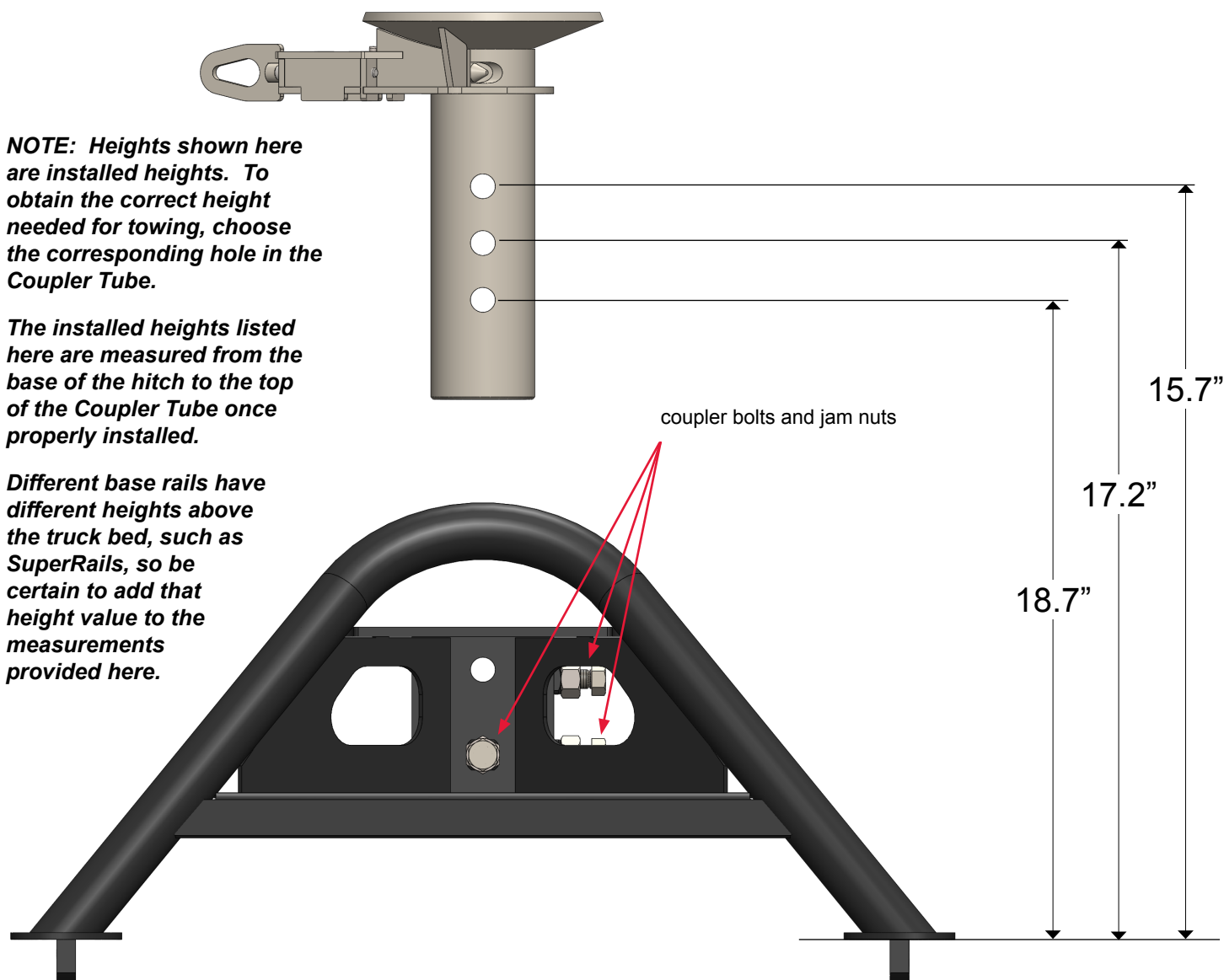

KING PIN ADAPTER INSTALLATION

1. Verify that the king pin is clean and free of burrs before installing the King Pin Adapter {A}. Remove any burrs with a flat file. If you are having fit issues, see “Challenge vs. Solution” on page 7.
2. Slide the King Pin Adapter over the king pin and install one Adapter Plate Bolt {A1} and Flat Washer {A3} horizontally through the smaller cross hole nearest the hitch ball (*right*). Install 1/2” Flange Nut {A4} and hand tighten only.

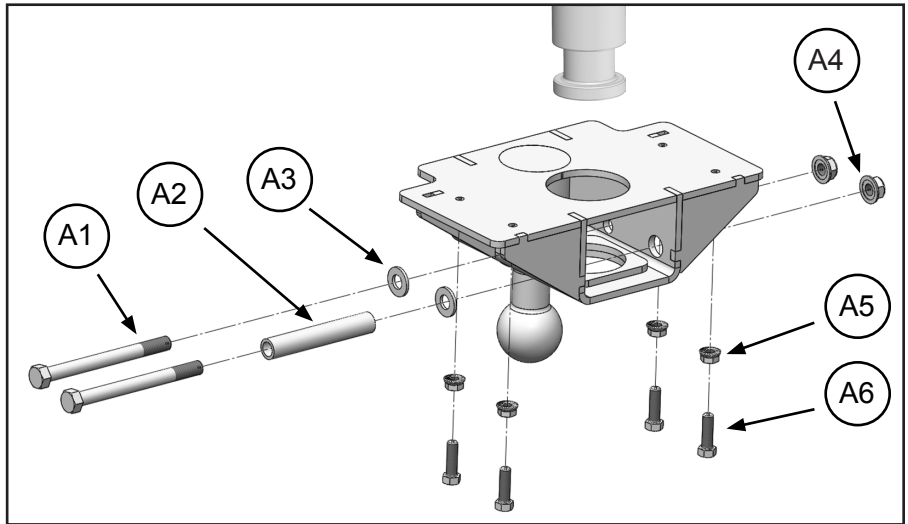

3. Install the Adapter Bolt Reinforcement Tube {A2} through the larger cross hole in the Adapter Plate, then the remaining Adapter Plate Bolt and Flat Washer through this tube. Install nut and snug by hand.
4. The adapter can be installed with the hitch ball offset in two positions—either ahead or behind the king pin. Determine the position you would like installed; placing the hitch ball ahead of the king pin will add additional cab clearance during tight turns, but does not guarantee total cab clearance for short bed trucks. Likewise, placing the ball behind the king pin will reduce the trailer-to-cab clearance. Orient the King Pin Adapter appropriately and make sure it's aligned parallel with the king pin box.
5. Tighten the four Adapter Plate Set Screws {A6} evenly with a 9/16” socket, and torque to 20 ft. lbs. *The gap between the King Pin Adapter and the king pin box's skid plate may be uneven due to several conditions, e.g., concave or convex skid plate or skewed king pins.*
6. Tighten the four 3/8” Flange Nuts {A5} until tight, approximately 20 ft. lbs.
7. Torque both Adapter Plate Bolts installed in Steps 2 & 3 to 75 ft. lbs.
8. Should you want to change the orientation of the adapter, it should only be necessary to loosen the Flange Nuts {A5} and Adapter Plate Set Screws, and rotate the Adapter Plate on the king pin. Loosening the remaining hardware should not be necessary most of the time.

HITCHING

WARNING: Never perform any of the following actions while any part of a person is between the vehicle and trailer.

1. Verify that the Latch Handle {B1} is pulled outward and rotated (left or right) into the latched open position (*right*). Damage could result should you attempt to hook up with the latch pin in the closed position.
2. Lower the trailer landing gear high enough to raise the ball above the top of the coupler funnel.
3. After lowering your truck tail gate, back the truck under the kingpin adapter to orient the ball above the funnel coupler (make sure there is space to completely back your truck into hitching position with the tail gate down). It is not necessary to be completely centered over the coupler, as long as the center of the ball is inside the diameter of the "funnel". The ball should slide toward the coupler tube when the trailer jacks are retracted.
4. Lower the trailer landing gear so the ball drops into the hitch coupler. The ball must be fully seated in the coupler to allow the latch mechanism to close properly.
5. Once the weight of the trailer is supported by the tow vehicle, use the latch handle to rotate the latch pin so that it retracts into the locked position. *Do not forget this step.*

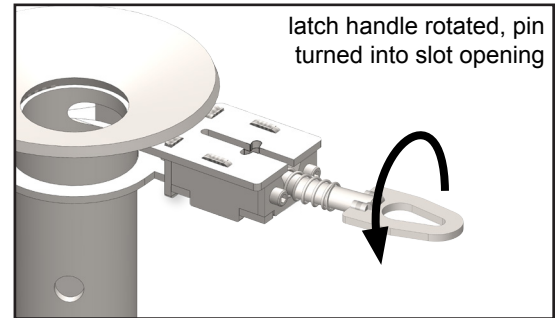
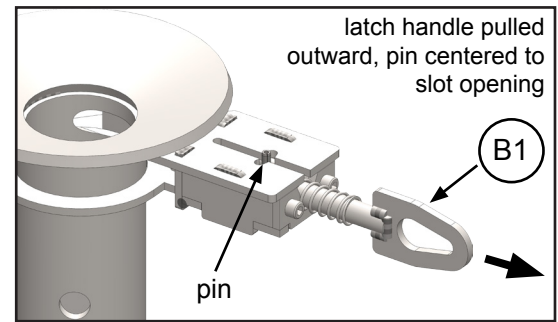

SAFETY CHECKS PRIOR TO TOWING

1. Prior to towing, it is imperative to know if are hooked up and the lock pin is engaged:
 - First, check the height of the King Pin Adapter; if seated properly below the Latch Pin, it will sit at the correct height (*top left*). If it's sitting higher than it should, you've either not lowered your trailer enough, or it's sitting *on top of* the Latch Pin inside the Coupler Tube.

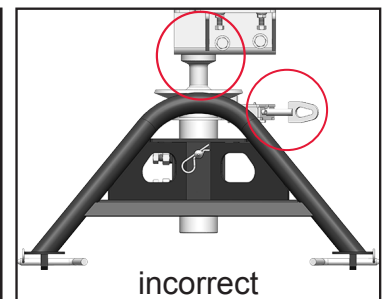
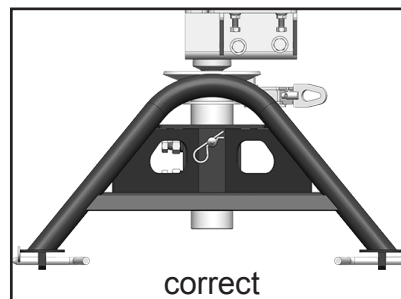

- Second, check the Latch Handle. If it is pulled outward in the open position, you've not secured the Lock Pin over the ball of the King Pin Adapter (*top right*).
2. Raise the trailer jack base plates just above the ground, lock your trailer brakes, then pull the tow vehicle slowly forward putting a strain on the trailer.
 3. When you are assured that the trailer is safely hooked up, raise your trailer jacks into their full retracted position.

FAILURE TO PERFORM THESE SAFETY CHECKS MAY RESULT IN DAMAGES TO TRUCK AND TRAILER.

UNHITCHING

WARNING: Never perform any of the following actions while any part of a person is between the vehicle and the trailer.

1. Once you have the trailer located and are ready to unhitch, block the trailer wheels so it will not roll back or forward.
2. Pull the Latch Handle {B1} towards the rear of the vehicle and rotate either clockwise or counter clockwise into the slotted opening as you did in the “Hitching” section. The latch pin must be retained in the open position to release the adapter ball from the tube.
3. Extend the trailer jacks until the ball is fully removed from the Coupler Tube {B} and above the top of the coupler funnel.
4. After lowering the truck’s tailgate, disconnect the trailer’s electrical cord and break-away switch cable, then pull forward.

CAUTION: If you find it necessary to reposition your trailer, you must follow the hitching procedures to ensure the hitch is latched before moving the trailer.

CHALLENGE VS. SOLUTION

CHALLENGE	SOLUTION
Cannot open the Latch Pin.	Should only be restricted if trailer is applying pressure to the pin. Raise trailer jacks to relieve ball pressure against pin.
My King Pin Adapter isn't fitting well over the king pin.	Paint or “crud” build up on the upper flange of the king pin (particularly near the junction of the king pin and skid plate), bent, skewed, or king pins that are too long or too short can cause a poor fit. Contact PullRite’s Customer Service Dept. at (800) 443-2307 and we’ll give you suggestions on how to correct it.
Trailer overhang is hitting the truck bed rails when the trailer and truck are at sharp angles.	Raise or lower the hitch coupler height and/or lower the king pin box. There should be at least 6” between the top of the bed rails and bottom of the trailer.
The latch handle mechanism seems too stiff to operate.	Spray the locking mechanism with WD-40. Work the handle until it slides freely. If the problem persists, you may need to degrease and re-lube all working parts.
I need to have a professional evaluate my SuperLite.	Contact PullRite’s Customer Service Dept. at (800) 443-2307. Your needs will be assessed and resolved by PullRite or you will be directed to an authorized PullRite Service Center.

#2400 EXPLODED VIEW

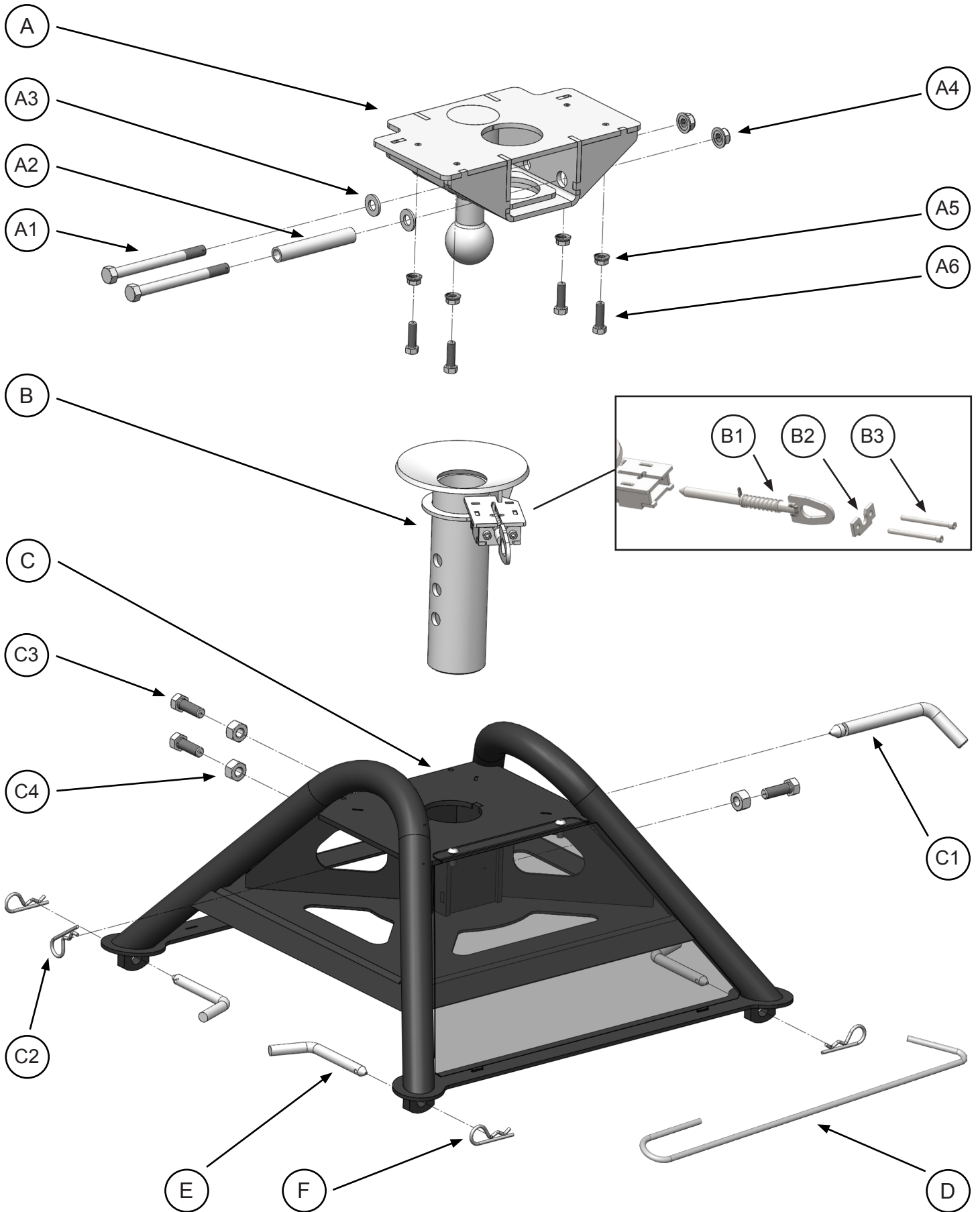

#2400 PARTS LIST

Item	Description	Part No.	Qty.	Description
A	KING PIN ADAPTER	2403	1	
B	COUPLER TUBE ASSEMBLY	2402	1	
C	HITCH BASE	2401	1	
D	RELEASE HANDLE	2405	1	
ADAPTER PLATE HARDWARE KIT -- 240302				
A1	ADAPTER PLATE BOLT	98010203	2	1/2"-13 X 5-1/2" HHCS GRD 5
A2	ADAPTER BOLT REINFORCEMENT TUBE	24030201	1	0.75 X 0.531 TUBE
A3	FLAT WASHER	98250147	2	1/2" FLAT WASHER
A4	1/2" FLANGE NUT	98150201	2	1/2"-13 SERRATED FLANGE NUT
A5	3/8" FLANGE NUT	98150168	4	3/8"-16 FLANGE NUT
A6	ADAPTER PLATE SET SCREWS	98010222	4	3/8"-16 X 1.25" BOLT
LATCH PIN ASSEMBLY				
B1	LATCH HANDLE	240205	1	HANDLE AND SPRING
B2	LATCH PIN HOUSING COVER	24020601	1	
B3	LATCH PIN HOUSING SET SCREWS	98410236	2	1/4"-20 X 2.75" SHCS ZINC
BASE HARDWARE KIT -- 240105				
C1	COUPLER TUBE PIN	010019	1	5/8" PIN, .625 DIA.
C2	COUPLER PIN CLIP	98410143	1	
C3	COUPLER TUBE SET BOLT	98010167	3	1/2"-13 X 1 1/2" BOLT
C4	COUPLER TUBE SET NUT	98150214	3	1/2"-13 HEAVY HEX NUT (7/8" HEX)
PINS AND CLIPS MOUNTING KIT -- 080601				
E	MOUNTING PIN	08060001	4	
F	MOUNTING PIN CLIP	98410127	4	
BASE RAIL KIT				
<i>PULLRITE INDUSTRY STANDARD BASE RAILS ARE SOLD SEPARATELY. CALL (800) 443-2307 FOR MORE INFORMATION.</i>				

TORQUE TABLE		
Hardware	Size	Torque Specs
Latch Pin Housing Set Screws	1/4"	5 ft. lbs.; factory assembled
Adapter Plate Set Screws	3/8"	20 ft. lbs.; both bolt and set nut, must be torqued <i>after</i> installing Adapter Plate Bolts
Coupler Tube Set Bolts	1/2"	45 ft. lbs.; both bolt and set nut
Adapter Plate Bolts	1/2"	75 ft. lbs.; torque <i>before</i> Adapter Plate Set Screws

5 YEAR LIMITED WARRANTY

PULLIAM ENTERPRISES, INC. hereinafter referred to as "PULLIAM", warrants to the first retail owner only, this PullRite towing system to be free from defects in materials and workmanship for a period of five (5) years or 31,068 miles (50,000 km) after the installation on purchaser's vehicle, whichever occurs first.

To validate this warranty, the first retail owner must mail the provided warranty card to PULLIAM, or register online at www.pullrite.com, within ten (10) days after installation of said towing system on his vehicle.

The owner is responsible for all normal and preventative maintenance described in the Owner's Manual.

If any defect occurs which the owner believes is covered by this warranty within said five (5) year period, the owner shall contact PULLIAM immediately, either in writing or by telephone call, Attention Customer Service Department. The owner will be instructed to return the hitch at his expense either to an authorized PullRite dealer or to PULLIAM to repair or replace any parts necessary to correct defects in material or workmanship.

Repair or replacement shall be at the sole option of PULLIAM and shall be completed by or on behalf of PULLIAM free of charge for materials and labor.

This warranty gives you specific legal rights, and you may also have other rights which vary from state to state.

THIS WARRANTY SPECIFICALLY *EXCLUDES* EACH OF THE FOLLOWING:

1. Defects in the product resulting from misuse, neglect, accident, loading beyond the vehicle's capacity, failure to comply with instructions contained in the Owner's Manual or unauthorized repairs, replacements, alterations or modifications. "Unauthorized repair, replacements, alterations" are those made without PULLIAM'S prior knowledge and consent.
2. Any incidental or consequential damage including, but not limited to, loss of use of the vehicle, towing charges, vehicle rental, loss of time, inconvenience, travel, gasoline, lodging and telephone expenses, loss of revenue and damages on account of personal injury and property damage. (Some states do not allow the exclusion or limitation of incidental or consequential damages, so these limitations may not apply to you).
3. Repairs or replacements of defects in any PullRite towing system, or part thereof, installed on any vehicle which has been rented, leased or used for any commercial purpose.
4. Any representation, warranty of undertaking made by any dealer or third party beyond the scope of the warranty herein expressed.
5. Any problem resulting in normal deterioration due to wear or exposure.

TO THE EXTENT PERMITTED BY LAW, IMPLIED WARRANTIES OF MERCHANTABILITY AND FITNESS FOR A PARTICULAR PURPOSE ARE LIMITED IN DURATION TO FIVE YEARS FROM THE DATE OF INSTALLATION ON THE FIRST OWNER'S VEHICLE. (SOME STATES, HOWEVER, DO NOT ALLOW LIMITATIONS AS TO DURATION OF IMPLIED WARRANTY, SO THOSE LIMITATIONS MAY NOT APPLY TO YOU)



Product Warranty Registration

As an owner of a PullRite product, you must register your product to be considered for warranty coverage. See Owners Manual for further details.

Please note, that you can also register online at www.pullrite.com/warranty.htm.

Name: _____

Address: _____

City: _____ State: _____ Zip: _____

Email Address: _____

Phone (optional): _____

Purchase Price: _____ Date of Purchase: _____

Dealer's Name: _____

Dealer's Address: _____

Dealer's City: _____ Dealer's State: _____ Dealer's Zip: _____

Dealer's Phone: _____

Model Purchased: _____

Vehicle Make: _____ Vehicle Model: _____ Vehicle Year: _____

Vehicle Year: _____ Vehicle Cab Style: _____ Vehicle Bed Length: _____

Did you receive an Owners Manual from the Dealer? Yes / No

What influenced you to buy your hitch? _____

Comments:



MANUFACTURED BY:

PULLIAM ENTERPRISES, INC.
13790 East Jefferson Blvd.
Mishawaka, IN 46545
(574) 259-1520 • (800) 443-2307
info@pullrite.com • www.pullrite.com